

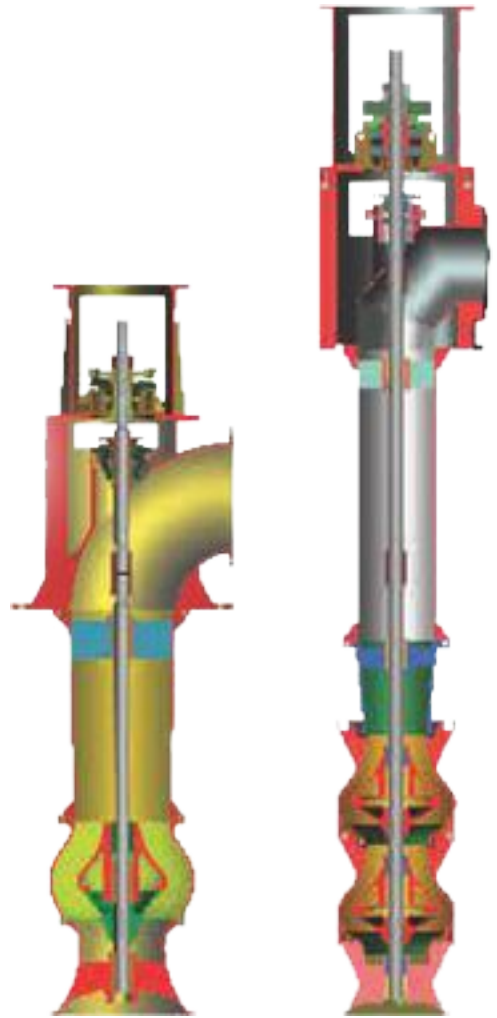

## Vertical Turbine Pumps



- Single Stage
- Multi Stage
- Axial Flow
- VTSP Pump



An ISO 9001 : 2015 Co.

[www.continentalindepthpumps.com](http://www.continentalindepthpumps.com)



## Description:-

- **Main Applications:**  
Water Supply, Lift irrigation, Power Plants, Sugar Mills Industry, Oil & Petro Chemical.
- **Discharge Column Size:**  
100mm to 800mm
- **Capacity:**  
Upto 5000m /hr
- **Head**  
Upto 250 mtrs
- **Maximum Speed**  
960,1480,2800 RPM (50 Hz)
- **Maximum Pressure:**  
Upto 30 Bar
- **Temperature:**  
Standard 80 C
- **Options:**  
Pull Out Design, Shaft enclosing Tube, w/1
- **Material:**  
Cast Iron, Ductile Iron, Bronze, Cast Steel, Ni Resist, (alloy steel on request)
- **Bearing Options:**  
Antifriction Bearings / General Bearings
- **Lubrications:**  
Grease or Oil / Water
- **Sealing:**  
Packed Gland (mechanical seal on request)
- **Types:**
  - \*Single stage & Multi stages.
  - \*Self / Water Lubricated & Oil Lubricated
  - \*'Y' Body Pumps ( upto 50qcs. capacity)



## **WHO WE ARE**

**Water is our Element**

### **WATER WISE**

Our products help you to control water wisely choosing new “green” technologies we are actually working in order to improve the quality of life.

**WE WANT TO CONTINUE THAT WHICH WAS STARTED MANY YEARS AGO BY MR. PARMANAND BALUJA, FOUNDER AND PIONEER.**

**BALUJA INDUSTRIES (India) IS A FAMILY OWNED COMPANY WITH AN HISTORY OF 51 YEARS**

Today, we are reality that has evolved over the years, always looking to the future with a spirit that has brought us to being a respected reference point in the great world of water.

we are committed to study, to develop, to manufacture and to industrialize pumping systems.



**Let's Solve Water**

**baluja Industries (INDIA)**

an ISO 9001:2015 Certified Company  
Email : [balujaindustriesindia@gmail.com](mailto:balujaindustriesindia@gmail.com)  
Web. : [www.continentalindepthpumps.com](http://www.continentalindepthpumps.com)

## WHO WE ARE

The True Spirit of ontinental Indepth

## ONTINENTAL - INDEPTH FAMILY

Group work and feeling of belonging to one big family are the distinguishly features of continental family which always celebrated company occasions as shared success and goals achieved thanks to the commitment of everyone.

**Our Group creates solutions where others see problems.**

Our Phenomenal success is based on:

Prompt, Tailor made services to suit client specific needs.

TOP-OF-THE-LINE Equipment at modest process, based

by PROMPT-AFTER-SALES-SERVICES



**Let's Solve Water**

**baluja Industries (INDIA)**

an ISO 9001:2015 Certified Company

Email : [balujaindustriesindia@gmail.com](mailto:balujaindustriesindia@gmail.com)

Web. : [www.continentalindepthpumps.com](http://www.continentalindepthpumps.com)

## WHAT WE DO....

### We Connect Water to People.

We manufacture high technology pumps and pump systems for a large variety of uses. As Under.



Agriculture



Irrigation



Power Generation



Lift-Irrigation

## Applications



Domestic



Industries



Ground Water



Petroleum

PUMPING GROWTH FOR  
**30 YEARS**

**baluja Industries (INDIA)**

an ISO 9001:2015 Certified Company  
Email : [balujaindustriesindia@gmail.com](mailto:balujaindustriesindia@gmail.com)  
Web : [www.continentalindepthpumps.com](http://www.continentalindepthpumps.com)

## How We Do It

The quality of our products is the quality of our people.

**CONTINENTAL** Indepth Quality : OUR PRODUCTION PLANTS ARE ONLY IN INDIA AND WE TEST EACH PRODUCT WE MAKE. WE BELIEVE IN MAKE IN INDIA

WE BELIVE IN TECHNOLOGY, WHICH CREATES VALUE FOR BOTH OURSELVES AND FOR THOSE WHO CHOOSE US.

We produce our pumps in india, Because we still believe in the quality of our people.

Motors are Received with Electric Data Sheets Provided by Manufacturer.

The growth reliability and strength of the entrepreneur is evident from its reputed clients. Which registered their faith in the product and appreciation of its performance by placing repeat order with us.



**baluja** Industries (INDIA)

an ISO 9001:2015 Certified Company

Email : [balujaindustriesindia@gmail.com](mailto:balujaindustriesindia@gmail.com)

Web. : [www.continentalindepthpumps.com](http://www.continentalindepthpumps.com)

## HOW WE DO IT.

We Can Boast On Our Performance Test,  
TEST-BEDS & Various of our VALUE CENTERS.

### TEST- BED

In house TEST-BED is our strength.

- ➔ Our test bed is equipped with watt meters, Amp Meter, Pressure Gauge, Techno meter, Volt Meter, frequency Meter, flow Meter.
- ➔ At a time 2 pump can be tested.
- ➔ The measuring instrument on the test bed are duly calibrated with pre-determined frequency.



**Let's Solve Water**

**baluja Industries (INDIA)**

an ISO 9001:2015 Certified Company  
Email : [balujaindustriesindia@gmail.com](mailto:balujaindustriesindia@gmail.com)  
Web. : [www.continentalindepthpumps.com](http://www.continentalindepthpumps.com)

## WHERE WE ARE

We build a long chain of Clients and Customers in Government and Private Sector Which Registered Their Faith In Us Again and Again by giving their orders

### Partial List of End-Users...

- ➔ Indian Oil Corporation (Refineries)
- ➔ Haryana Vidyut parsaran (Thermals)
- ➔ Nepal Electricity Authority (Nepal)
- ➔ UJVN Ltd. (U.K.)
- ➔ Larsen & Toubro (India)
- ➔ PUDA (Punjab)
- ➔ J&K State Electricity Authority
- ➔ SJVN
- ➔ Bharat Petroleum.
- ➔ Co-operative Sugar Mills (U.P. & Haryana)
- ➔ Uttar Pardesh Jal Nigam
- ➔ Local Bodies (M.P)
- ➔ Water Services Department (Haryana)
- ➔ Marketing Board (Haryana)
- ➔ Nepal Jal Sansthan (Nepal)

*& Many More.....*



**baluja Industries (INDIA)**

an ISO 9001:2015 Certified Company  
Email : [balujaindustriesindia@gmail.com](mailto:balujaindustriesindia@gmail.com)  
Web. : [www.continentalindepthpumps.com](http://www.continentalindepthpumps.com)



## HERE ALSO WE ARE....



# BE THE BEST

**baluja Industries (INDIA)**

an ISO 9001:2015 Certified Company  
Email : [balujaindustriesindia@gmail.com](mailto:balujaindustriesindia@gmail.com)  
Web . : [www.continentalindepthpumps.com](http://www.continentalindepthpumps.com)

## **OUR PRODUCTION UNITS AND SERVICE STATIONS....**

**To provide the better services and to maintain the close contacts to our clients we established VALUE CENTRE :**

### **At Safidon (HRY)**

Railway Road, Safidon-126112 (HRY)

Contact Person : Mr. T.R. Baluja  
9467785945

### **At Panipat (HRY)**

Test Labs & Sales Office

Assand Road, Panipat - 132103 (HRY)

Contact Person : Er. Mohit Kumar  
9416276895



## **WATER PASSION**

**baluja Industries (INDIA)**

an ISO 9001:2015 Certified Company  
Email : [balujaindustriesindia@gmail.com](mailto:balujaindustriesindia@gmail.com)  
Web. : [www.continentalindepthpumps.com](http://www.continentalindepthpumps.com)

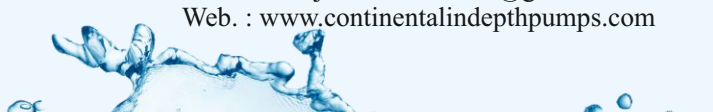



**NOW IN POWER INDUSTRIES**

**Vertical Pumps**  
**Vertical Axial Flow**  
**Vertical Mix Flow**  
**Vertical Turbines**



**WATER PASSION**

**baluja Industries (INDIA)**

an ISO 9001:2015 Certified Company  
Email : [balujaindustriesindia@gmail.com](mailto:balujaindustriesindia@gmail.com)  
Web. : [www.continentalindepthpumps.com](http://www.continentalindepthpumps.com)



**Axial Flow  
Pump**



**Axial Flow  
Y Body Pump**

**baluja Industries (INDIA)**

an ISO 9001:2015 Certified Company  
Email : [balujaindustriesindia@gmail.com](mailto:balujaindustriesindia@gmail.com)  
Web. : [www.continentalindepthpumps.com](http://www.continentalindepthpumps.com)



**CONTINENTAL** Indepth  
Pumps

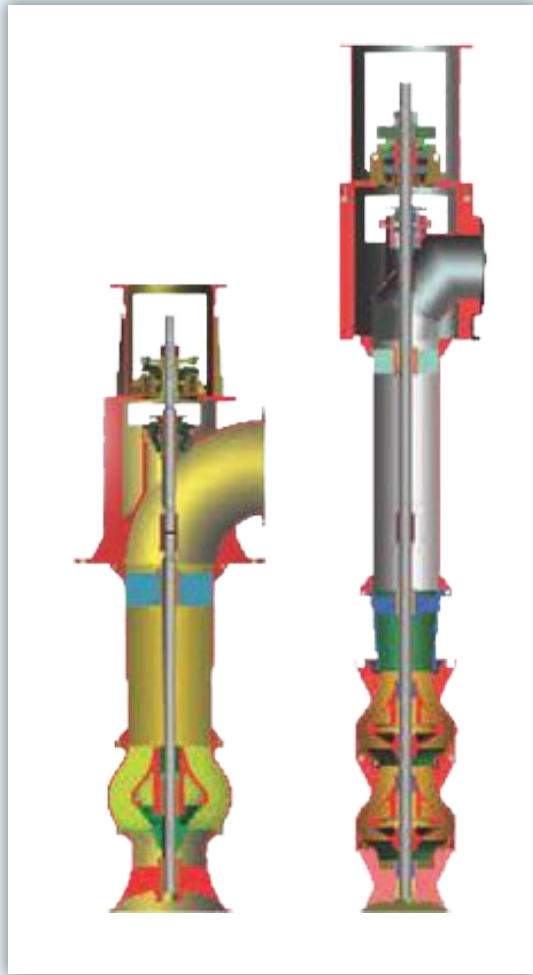

**90°  
Surface Head**

**VSP Sump  
Pump**



**baluja Industries (INDIA)**

an ISO 9001:2015 Certified Company  
Email : [balujaindustriesindia@gmail.com](mailto:balujaindustriesindia@gmail.com)  
Web. : [www.continentalindepthpumps.com](http://www.continentalindepthpumps.com)





**End Suction  
PUMP**

**Dewatering  
Submersible  
PUMP**



**baluja Industries (INDIA)**

an ISO 9001:2015 Certified Company  
Email : [balujaindustriesindia@gmail.com](mailto:balujaindustriesindia@gmail.com)  
Web. : [www.continentalindepthpumps.com](http://www.continentalindepthpumps.com)

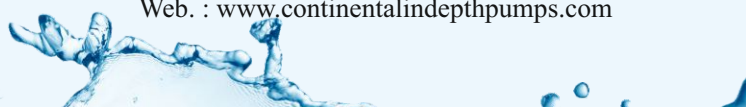



## Engine Driven VT Multipurpose Pump



## Right Angle Gear Head

**baluja** Industries (INDIA)

an ISO 9001:2015 Certified Company

Email : [balujaindustriesindia@gmail.com](mailto:balujaindustriesindia@gmail.com)

Web. : [www.continentalindepthpumps.com](http://www.continentalindepthpumps.com)



# CONTINENTAL Pumps Indepth

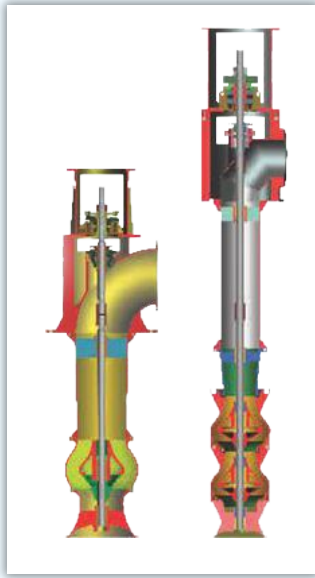

## OUR RANGE OF PUMPS



**baluja Industries (INDIA)**

an ISO 9001:2015 Certified Company  
Email : [balujaindustriesindia@gmail.com](mailto:balujaindustriesindia@gmail.com)  
Web. : [www.continentalindepthpumps.com](http://www.continentalindepthpumps.com)





## OUR RANGE OF PUMPS

S. No.	Pump Types	Size in MM	Capacity M3 / HR	Head range Meters
1.	Vertical Turbine (Single Stage) Mixed Flow	100-1200	Upto 4000	26
2.	Vertical Turbine (Multi Stage) Mixed Flow	100-1200	Upto 5000	250
3.	Vertical Axial Flow (Single Stage)	100-3000	Upto 5000	15
4.	Vertical Split Case (Single Stage)	50-300	Upto 3000	60
5.	Horizontal End Suction Back Pull Out Process Pumps	32-250	Upto 1000	125
6.	Horizontal End Suction Back Pull Open Impeller Pumps	32-250	Upto 1000	50
7.	Horizontal Split Casing Single Stage	50-500	Upto 5000	80
8.	Horizontal Split Casing Two Stage	50-400	Upto 3500	200
9.	Dewatering Submersible Pumps	50-350	Upto 5000	3-23

### Approved by :

1. **U.P. Jal Nigam**
2. **Govt. of Jammu & Kashmir**
  - a. J&K State Power Development Corporation
  - b. PHED Mech. Procurement Department
  - c. J&K Irrigation
3. **State Govt. of Chattisgarh, Kerala, Haryana & Bihar**
4. **Uttarakhand Jal Vidyut Nigam**
5. **Center Govt. Undertakings**
  - a. NHPC
  - b. Hindustan Copper Corp. of India
  - c. Uttarakhand Jal Sansthan
6. **Exports**
  - A. Nepal**
    - a. Nepal Electricity Authority
    - b. Nagar Palika-Bhariya (Nepal)
  - B. South Africa**
    - a. Star Gold Africa
  - C. Nizeria - Marcus Agubata**  
And Many More....

**baluja Industries (INDIA)**

an ISO 9001:2015 Certified Company  
Email : balujaindustriesindia@gmail.com  
Web. : www.continentalinddepthpumps.com



**CONTINENTAL** Indepth  
Pumps

**Values we nurture**

**Care**

**Innovation**

**Passion**

**Trust**

**baluja** Industries (INDIA)



## Oil - Lubricated

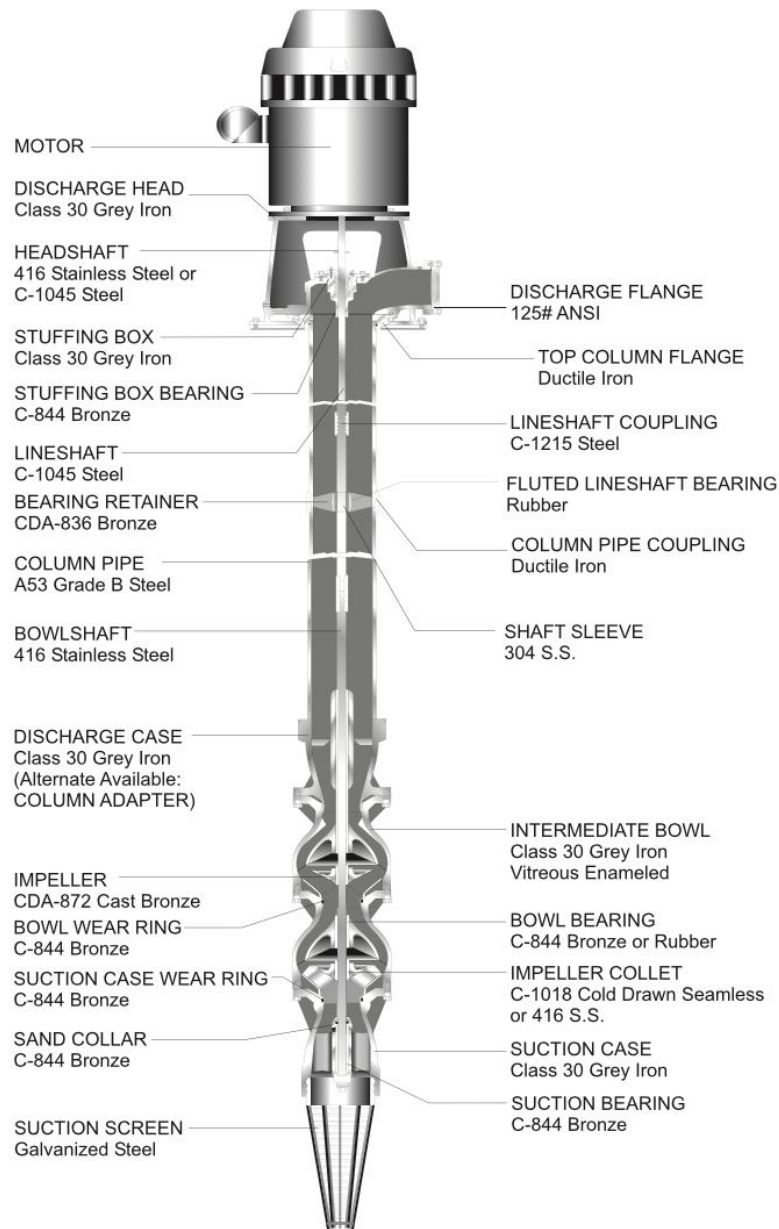

**baluja Industries (INDIA)**

an ISO 9001:2015 Certified Company

Email : [balujaindustriesindia@gmail.com](mailto:balujaindustriesindia@gmail.com)

Web. : [www.continentalindepthpumps.com](http://www.continentalindepthpumps.com)



## **baluja** Industries (INDIA)

Add. : Railway Road, Safidon-126112 (HARYANA)

Test Lab & Sales Office : Near St. Marry Church, Assandh Road, P.O. Shodapur, Panipat-132103

Tel. : +91 9467785945 Email : [balujaindustriesindia@gmail.com](mailto:balujaindustriesindia@gmail.com)

Web. : [www.continentalindepthpumps.com](http://www.continentalindepthpumps.com)